

60 min

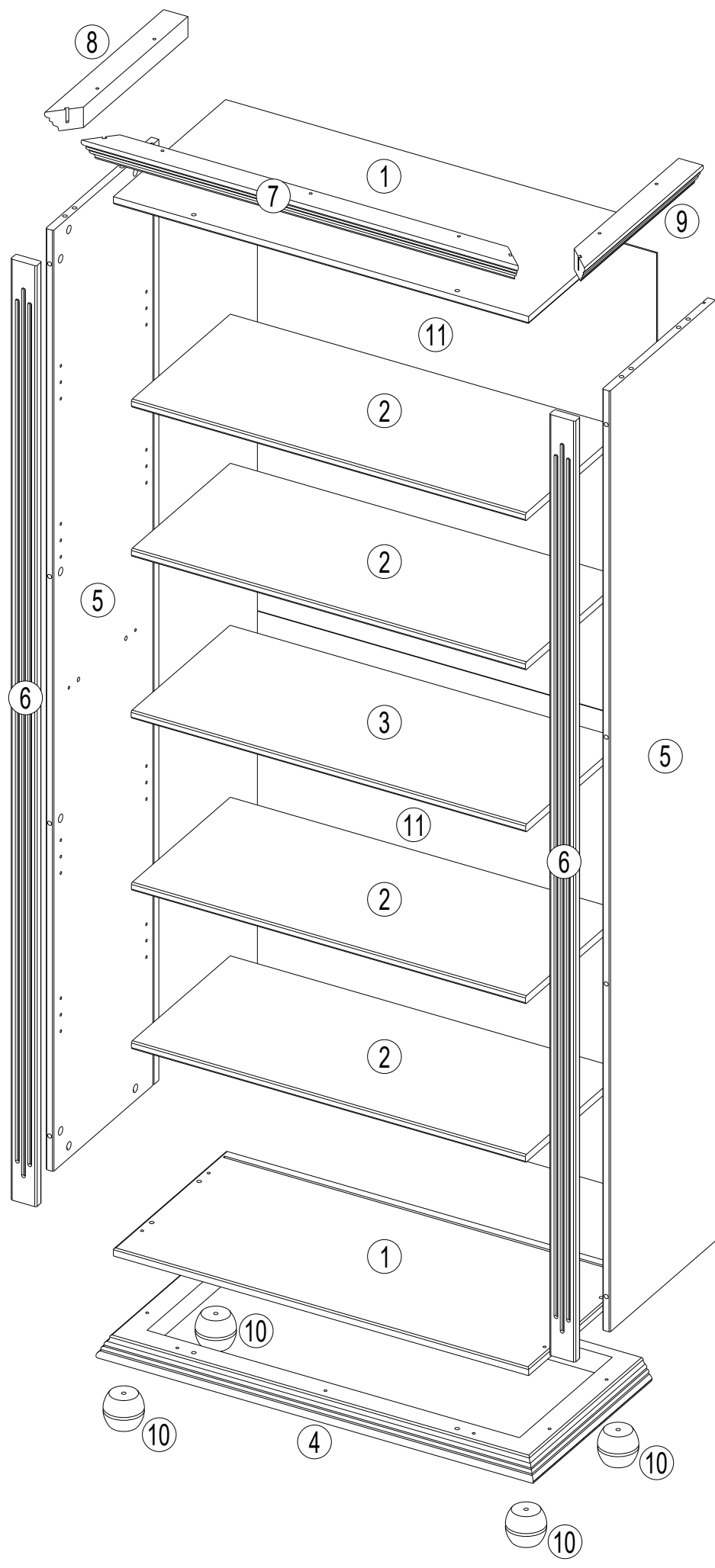

2

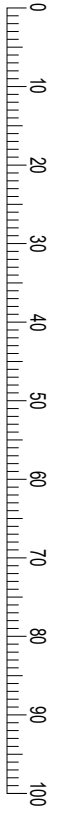
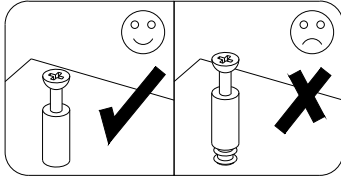
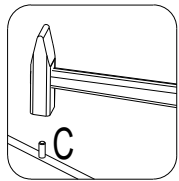
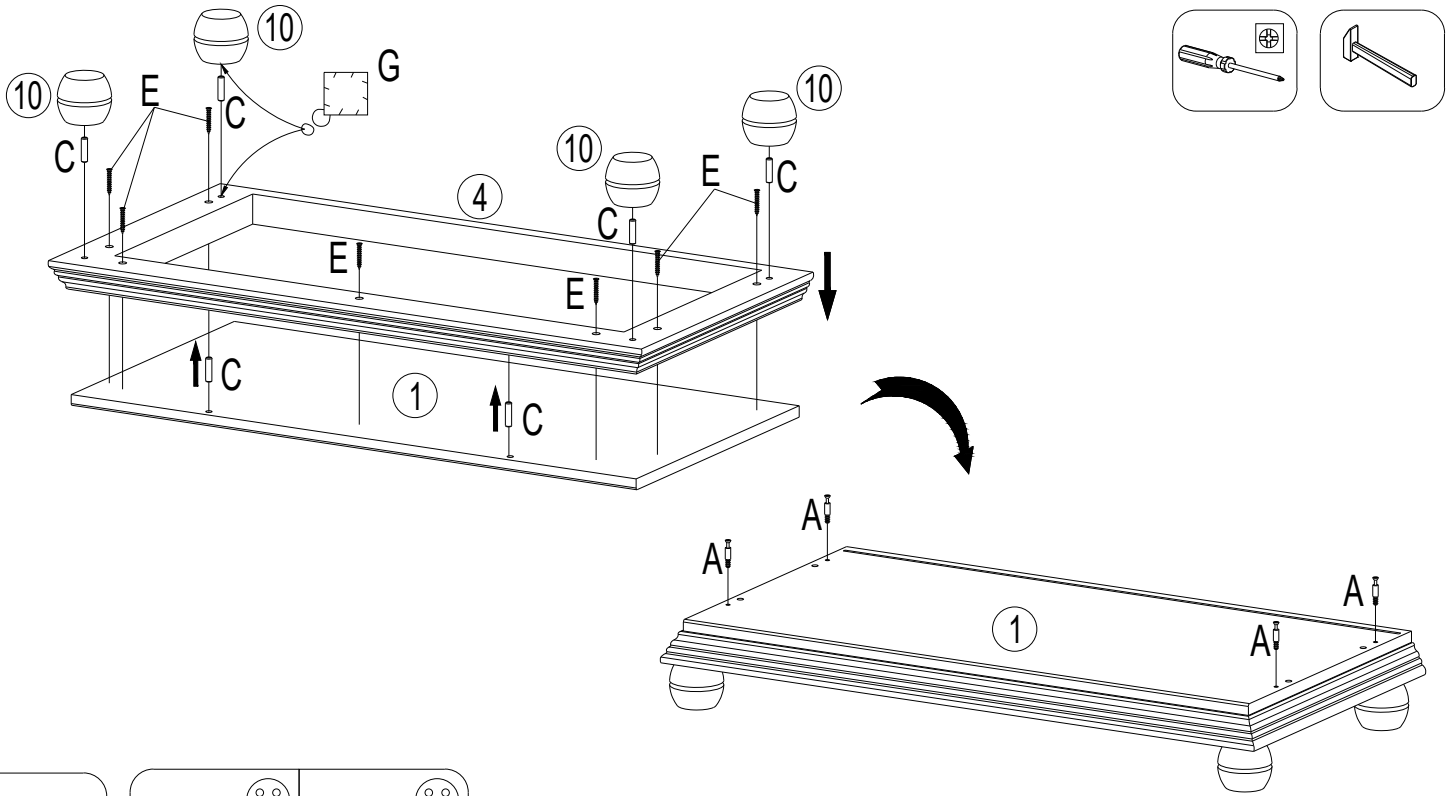
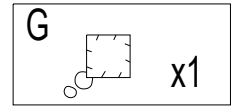
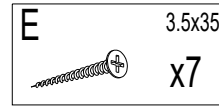
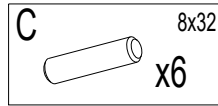
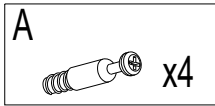

3

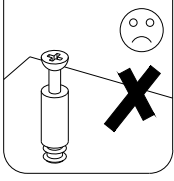
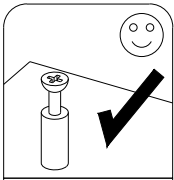
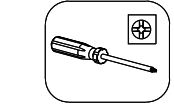
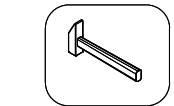
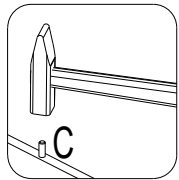
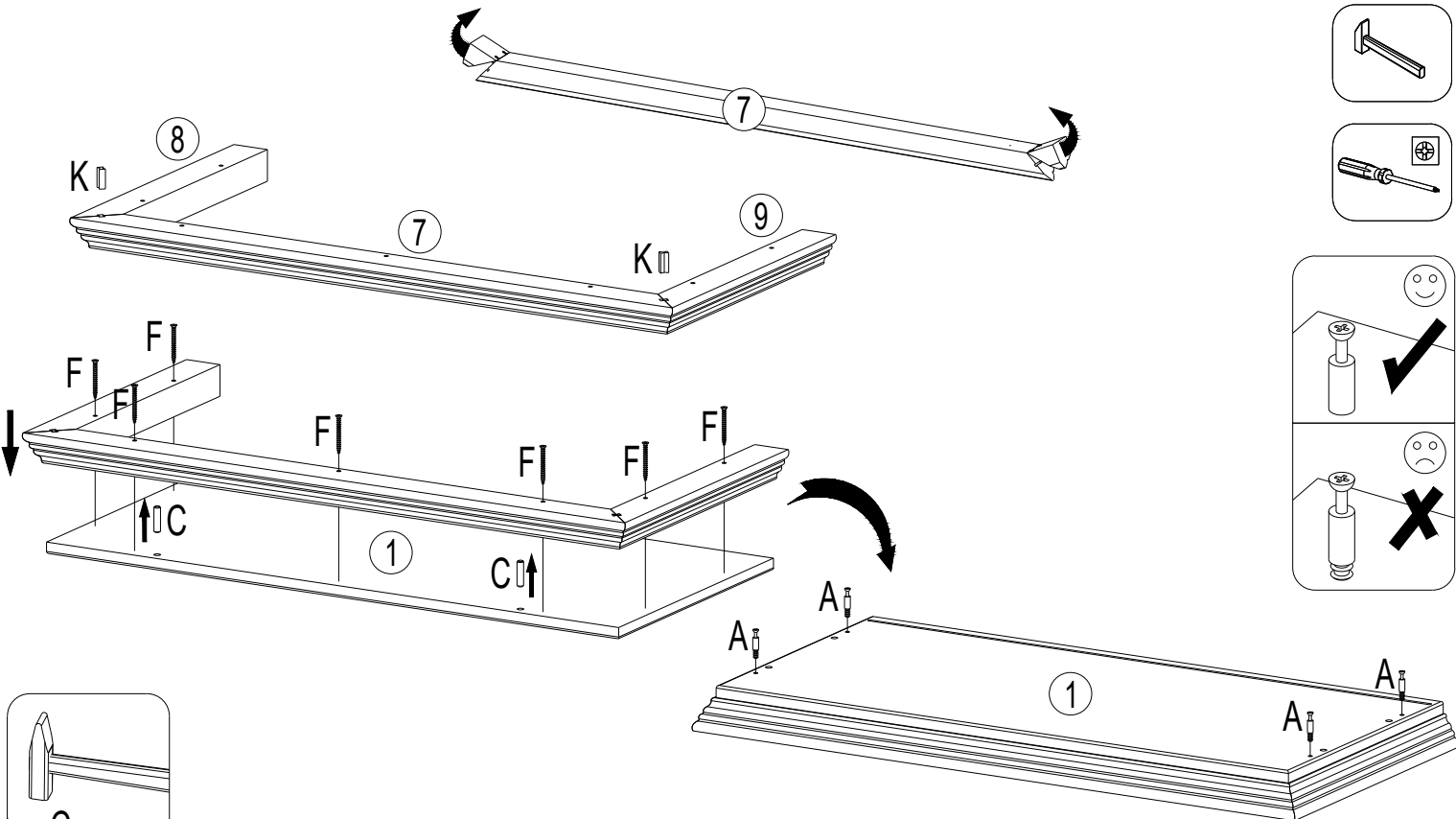
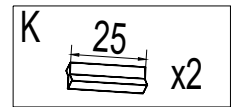
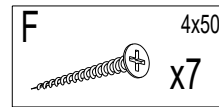
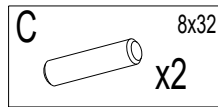
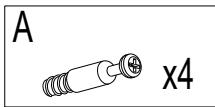

4

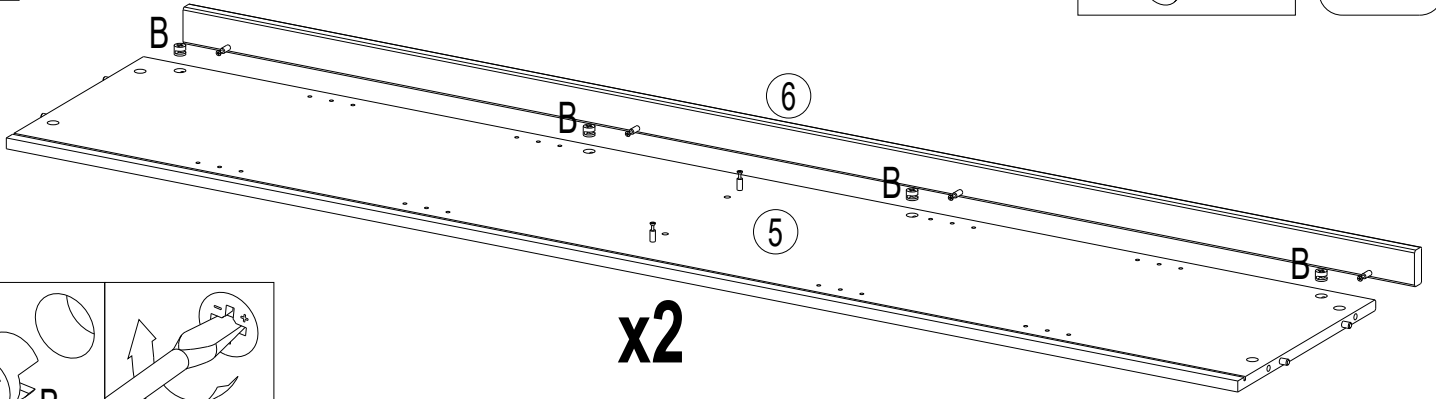
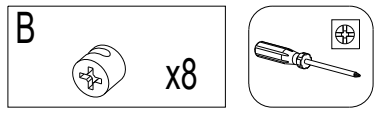

x2

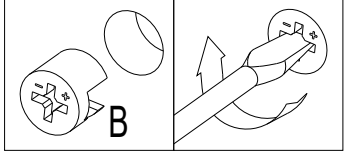

5

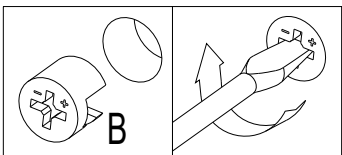
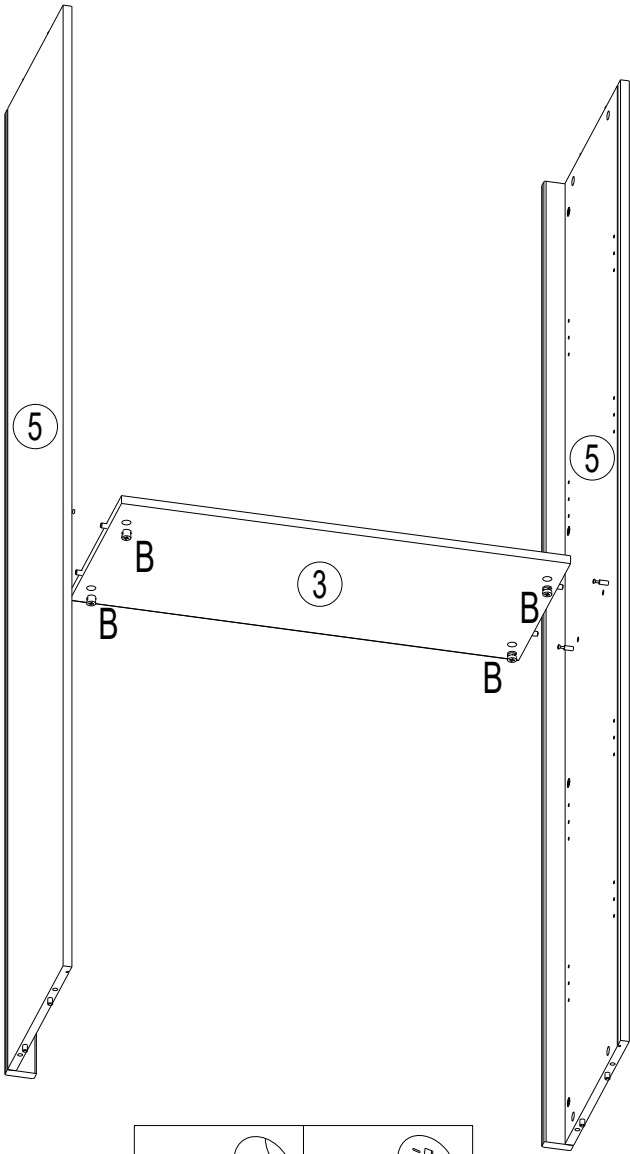
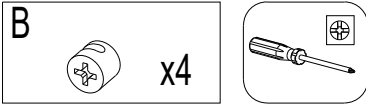

6

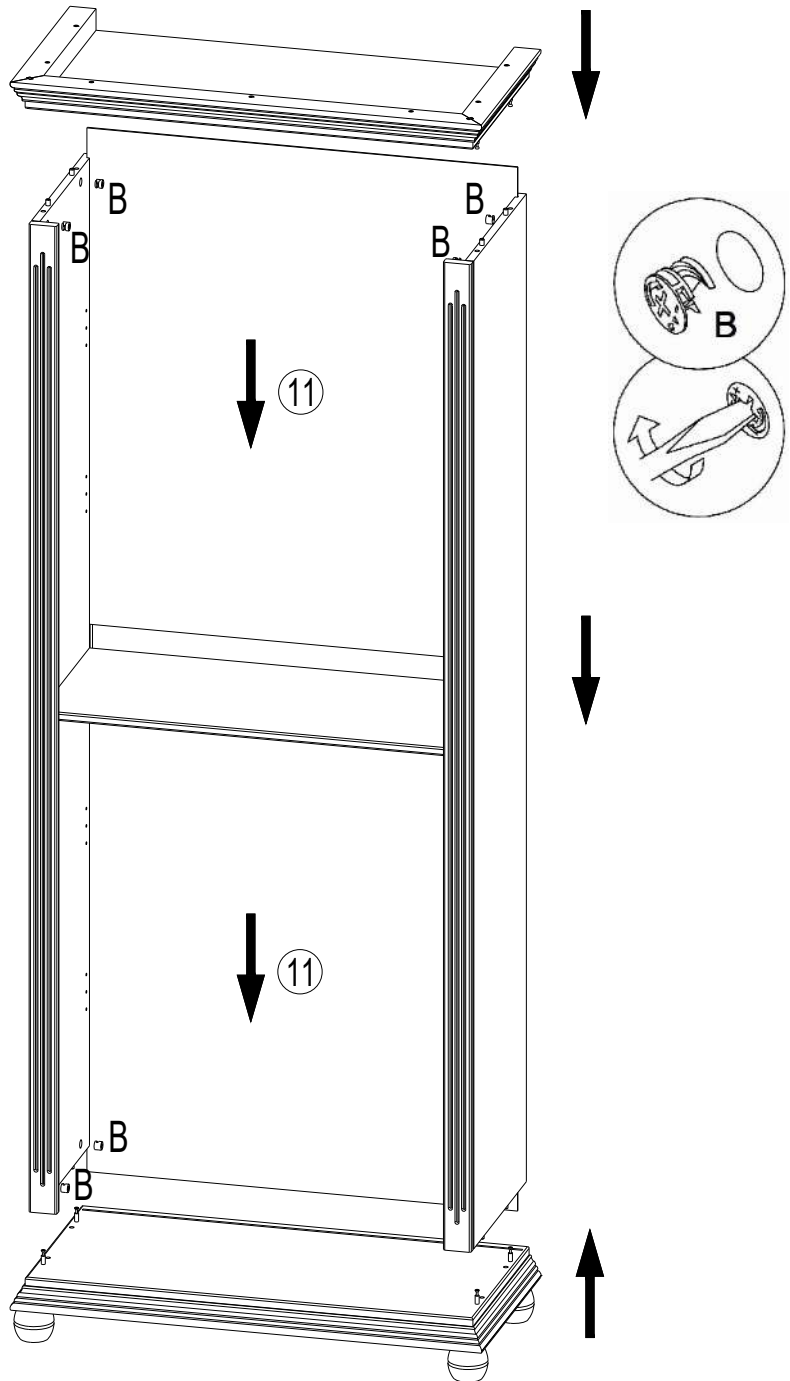
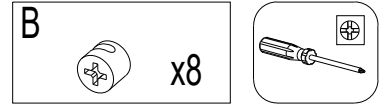

5-6

7

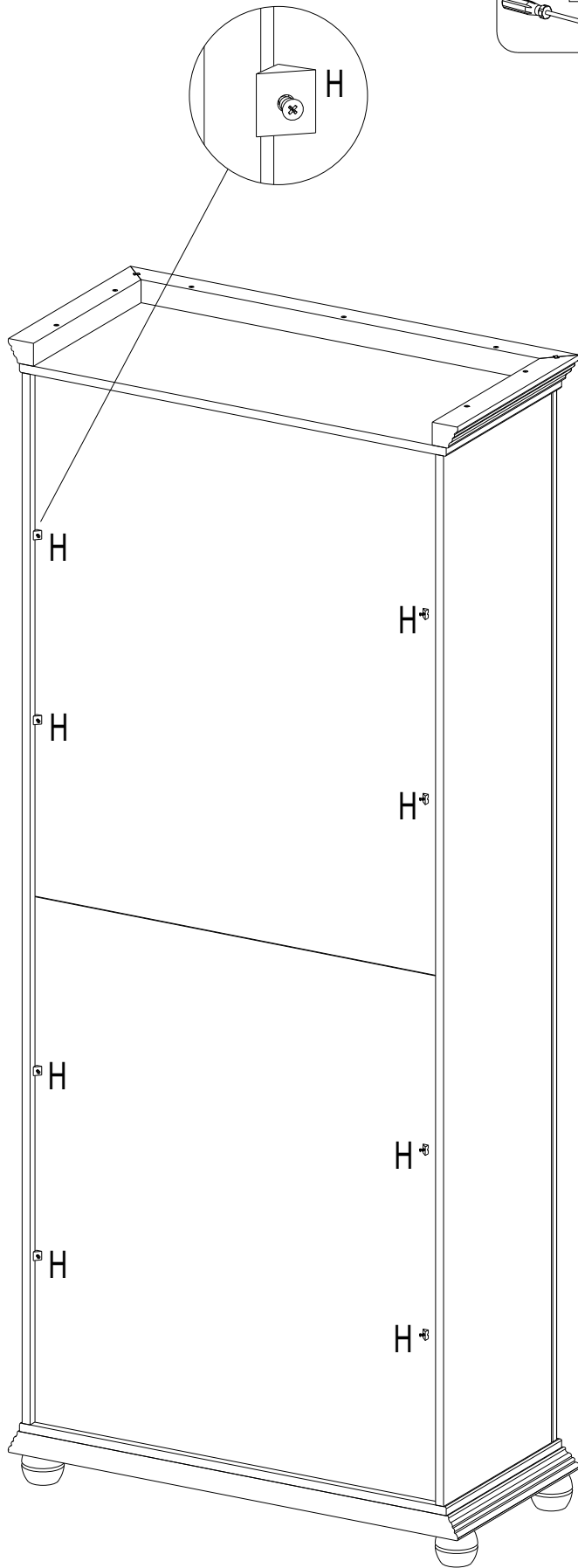
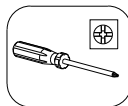
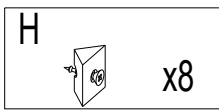

8

